



GX4



NYALIC
Clear Surface Protectant

Gear Boxes coated in Nyalic to help prevent corrosion.

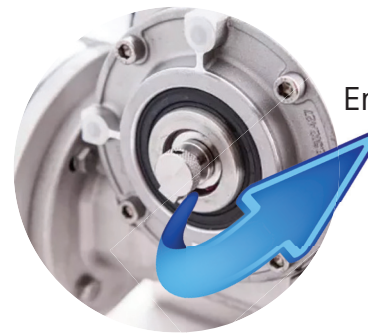
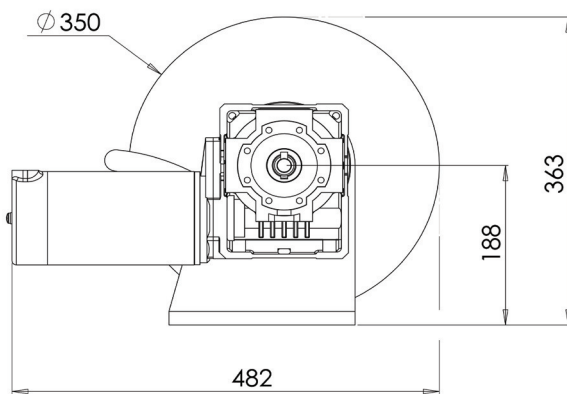

Emergency manual release

The GX4 is the answer for large capacity trailer boat and commercial fishermen. This model has been created for XHD loads and structural integrity with a 37mm solid machined shaft, 8mm frame, and 25mm solid frame stiffener. Thanks to the well oversized gearing and motor, this unit can easily be fitted to boats to 12m for saltwater use and much larger for freshwater applications.

- Huge 1500W (12V) or 2000W (24v) motor
- Perfect for wet wells and deck mounts
- Boats to 12m
- Fast drop/retrieval rating
- Sealed IP68 motor and oversized gearbox
- 8mm 316SS plate construction
- Emergency manual release
- 44kg approximate weight of unit

Installation kit includes: 316 stainless steel backing plate, 400amp solenoid, 150amp circuit breaker, switch and panel, nuts and bolts.

Model	Motor Size	Drop/Retrieve	Max Pull (Empty Drum)	Max Pull (Full Drum)	Recc. Max Working Load	Rope/ Chain Capacity	Boat Size (metres)	Holding at Anchor
GX4 350mm drum	1500watts (12volt) 2000watts (24volt)	46metres per minute	1987kg	413kg	120kg	120m x 10mm + 10m x 8mm	8-12	5.2T